

Monte Carlo Simulations of Space Plasmas

A. R. Barakat and R. W. Schunk

*Center for Atmospheric and Space Sciences
Utah State University, Logan, Utah
USA*

(June, 2007)

Outline

- 1. Overview of the technique**
- 2. 0-D (homogeneous) problems**
- 3. 1-D problems**
- 4. 3-D problems**
- 5. Efficiency improvement techniques**
- 6. Summary**

1. Overview of the Technique

1.a. A Simple Example

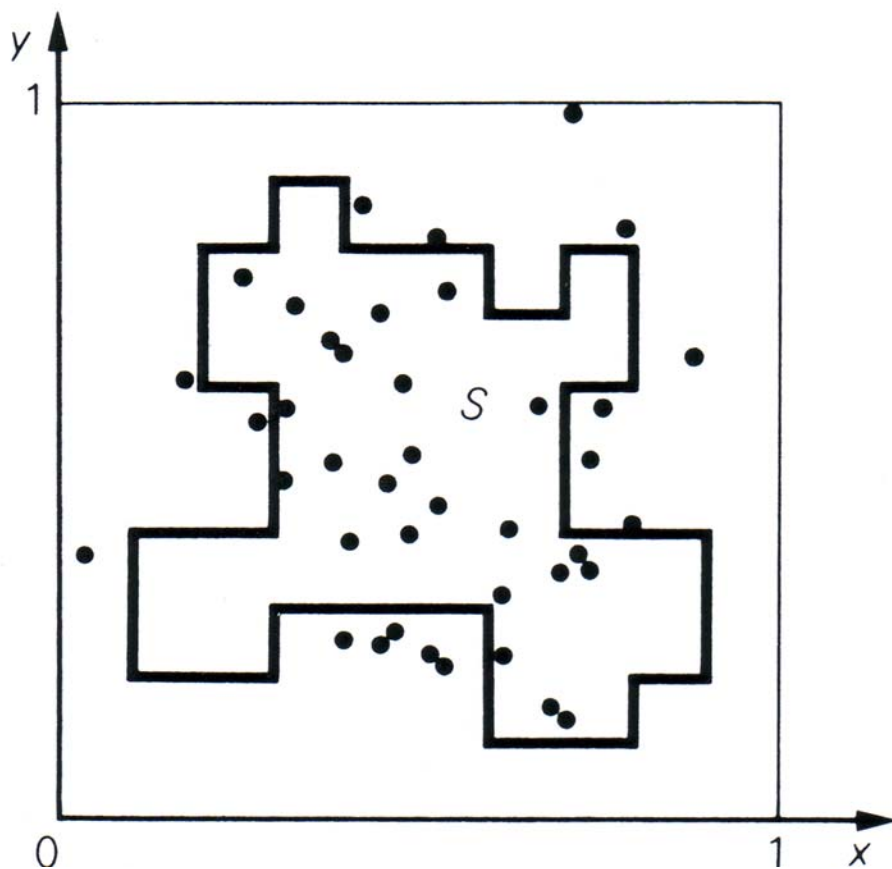

$$S_N = (N_{in}/N)$$

$$S = \lim S_N \quad \text{as } N \rightarrow \infty$$

$$\sigma(S_N) \sim (N_{in})^{-1/2}$$

1.b. Random and Pseudo Random Numbers

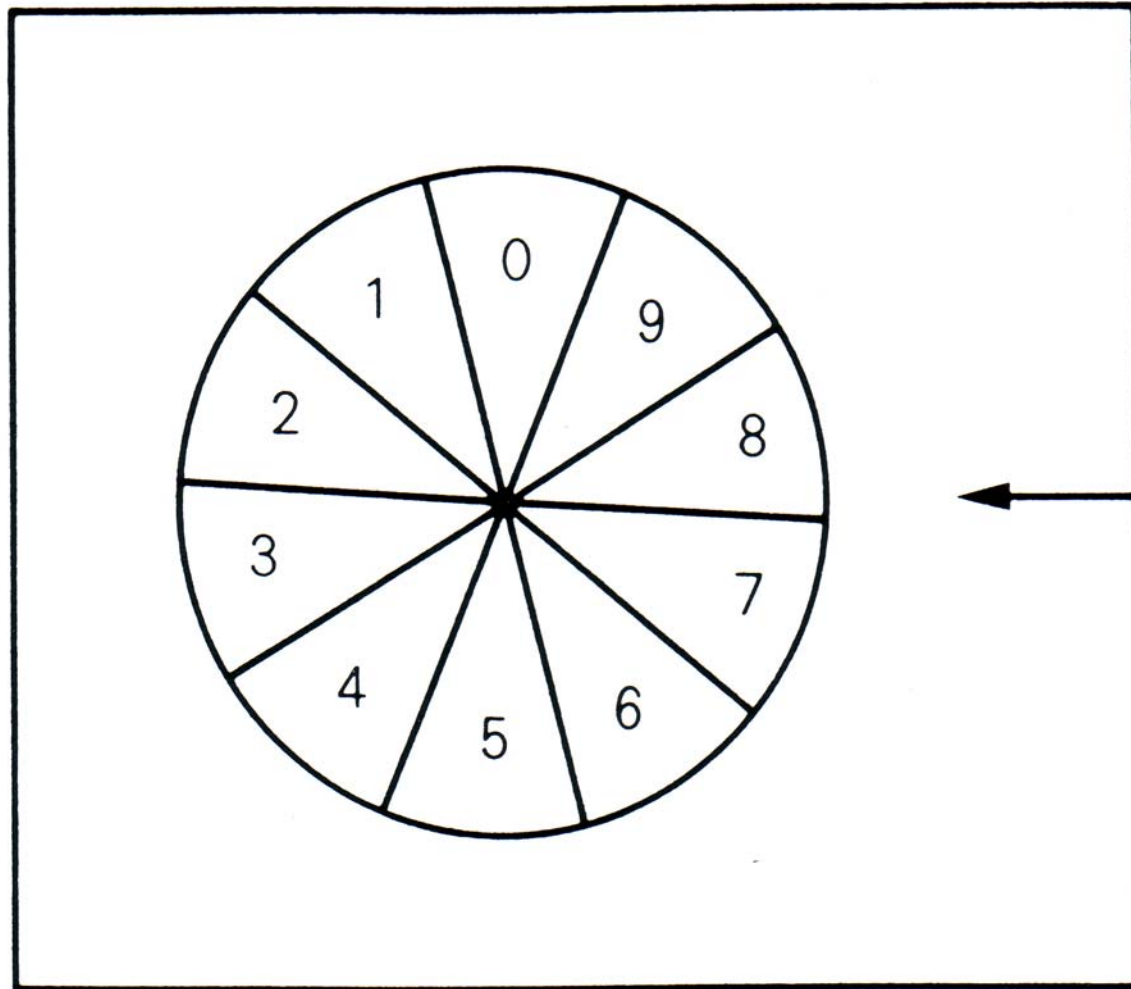

- A typical random number generator:

$$n_1 = 9876 \qquad (n_1)^2 = 97\mathbf{5353}76$$

$$n_2 = 5353 \qquad (n_2)^2 = 28\mathbf{6546}09$$

$$n_3 = 6546 \qquad (n_3)^2 = \dots$$

0.9876, 0.5353, 0.6546, ...

- Advantage of pseudo-random numbers
 - Reproducible
 - Testable
 - Practical

2. Zero-D Problems

2.a. Ions Drift with $E \gg$

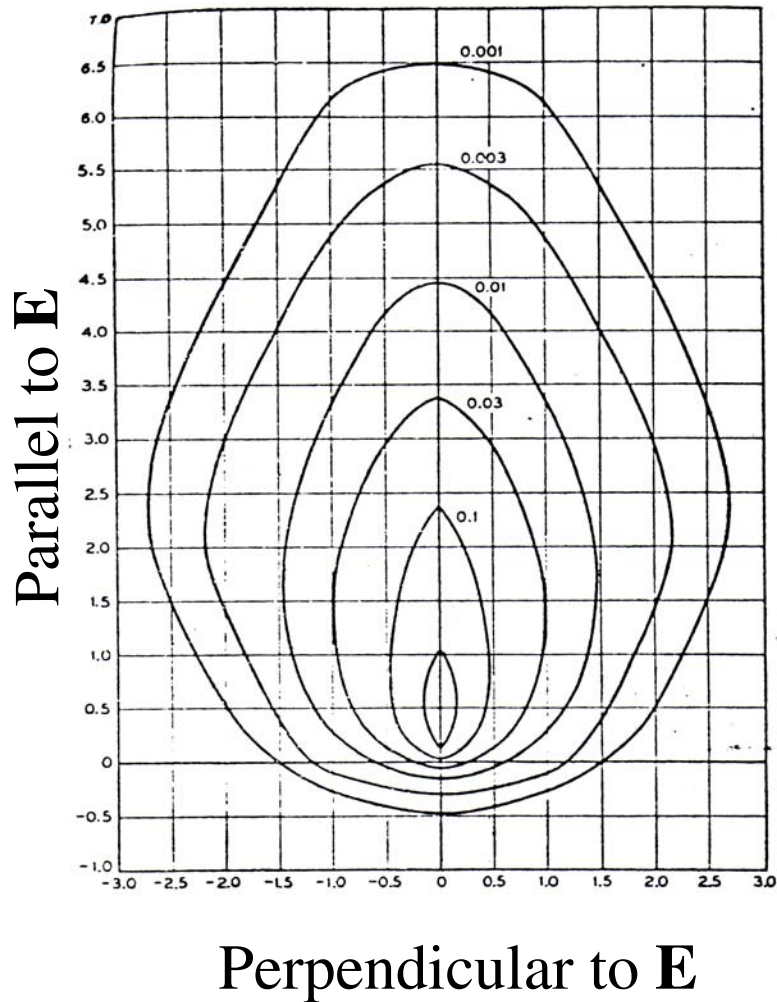

- Const. mean free time
- Isotropic scattering
- 10,000 collisions
- Semi-manual

[Wannier, 1953]

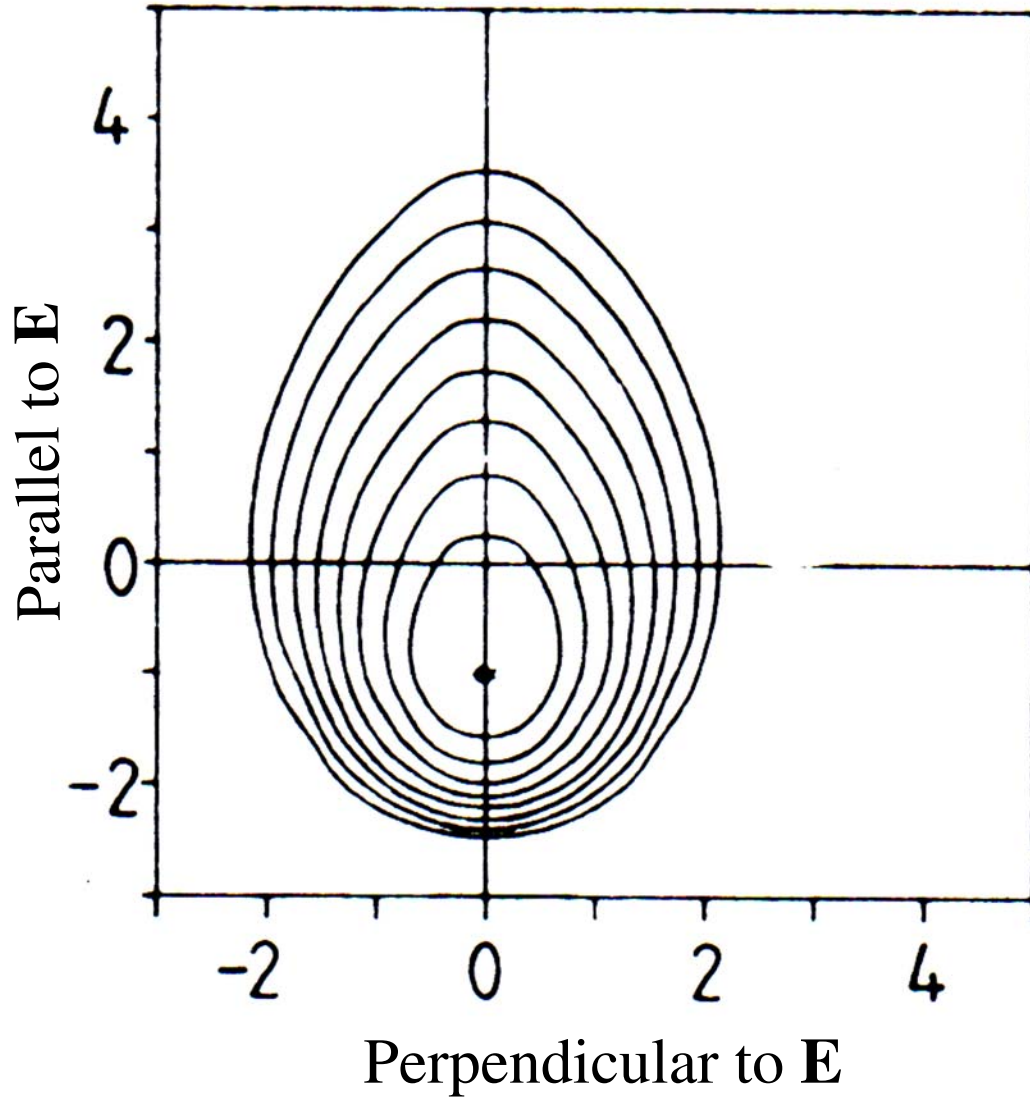

- 100,000 collisions
- Automated

[Barakat and Schunk, 1982]

2.b. Auroral O^+ VDF

- $\mathbf{E} \perp \mathbf{B}$
- Resonance charge exchange and polarization collisions
- $v(O^+-O) \ll \Omega(O^+)$

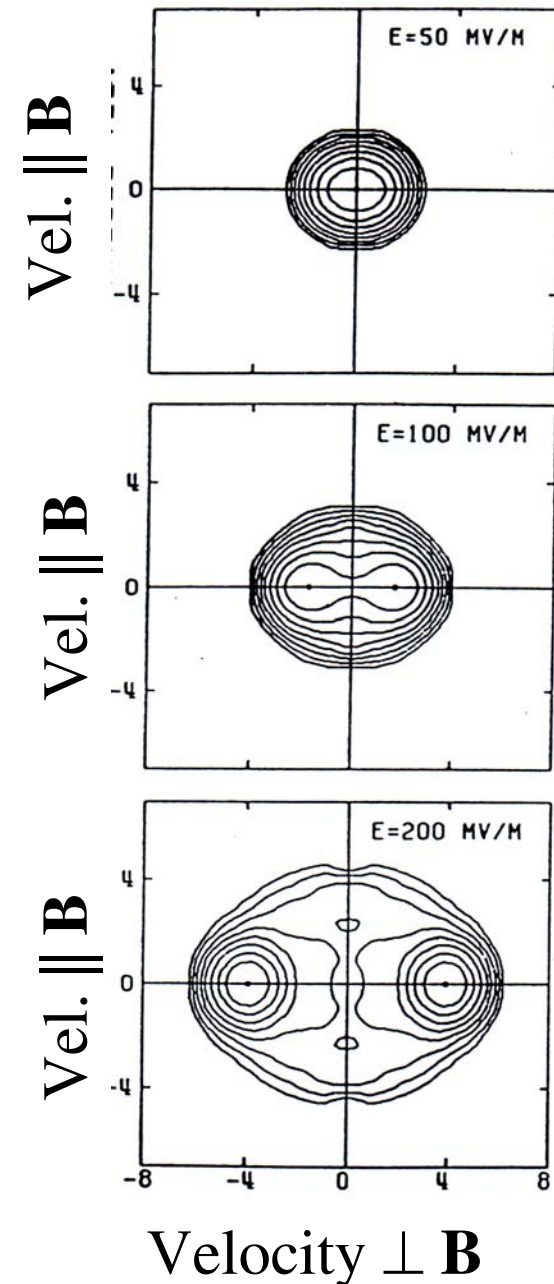

[Barakat et al., 1983]

3. 1-D Problems

3.a. Milne Problem

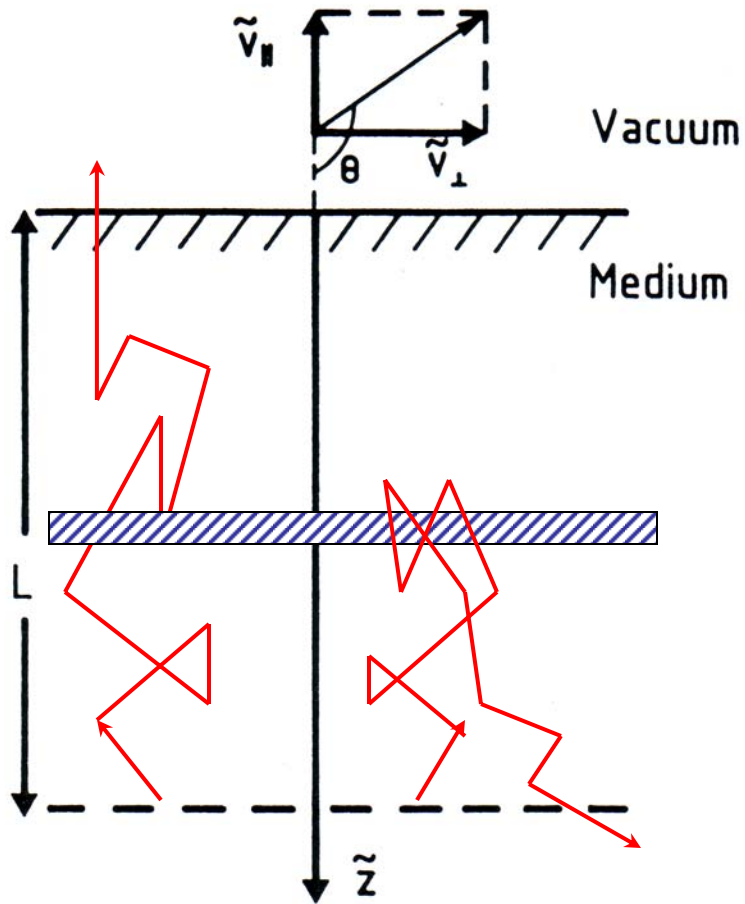

- $\tilde{z} = z / m.f.p.$
- $n_b = const.$ for $\tilde{z} > 0$
- $n_b = 0$ for $\tilde{z} < 0$
- $L \gg 1$
- $n \sim \sum_i (\delta t)_i$

Hard Sphere

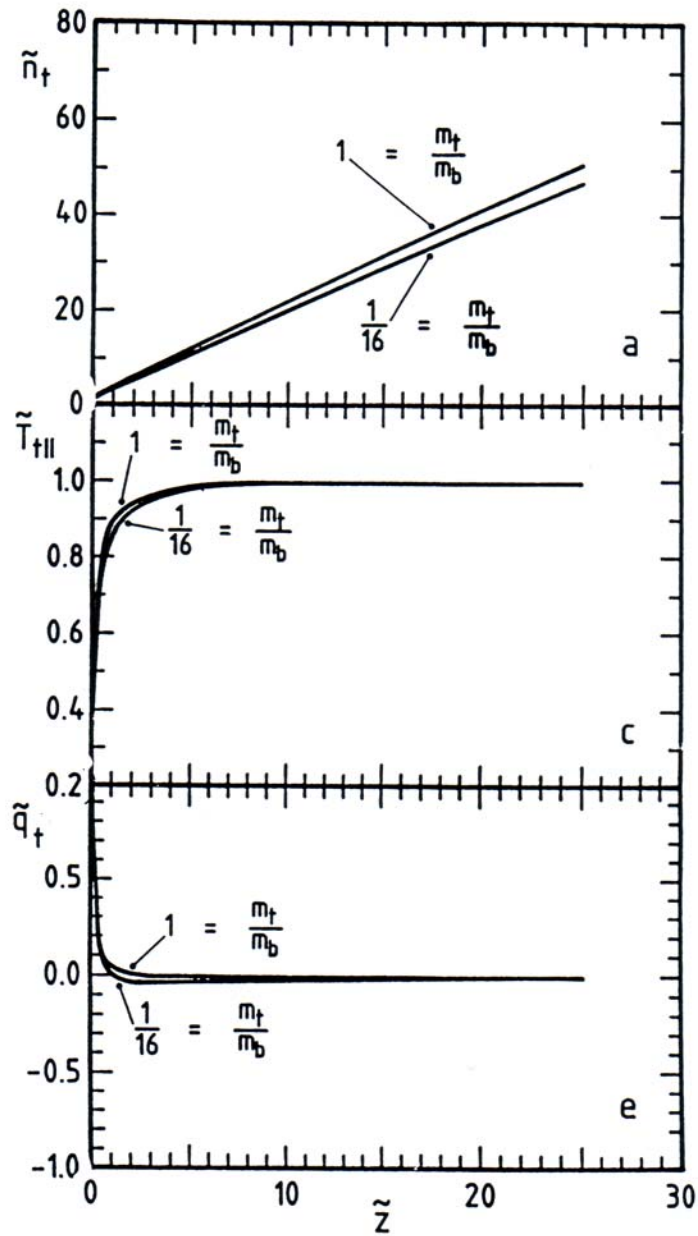

Coulomb Collision

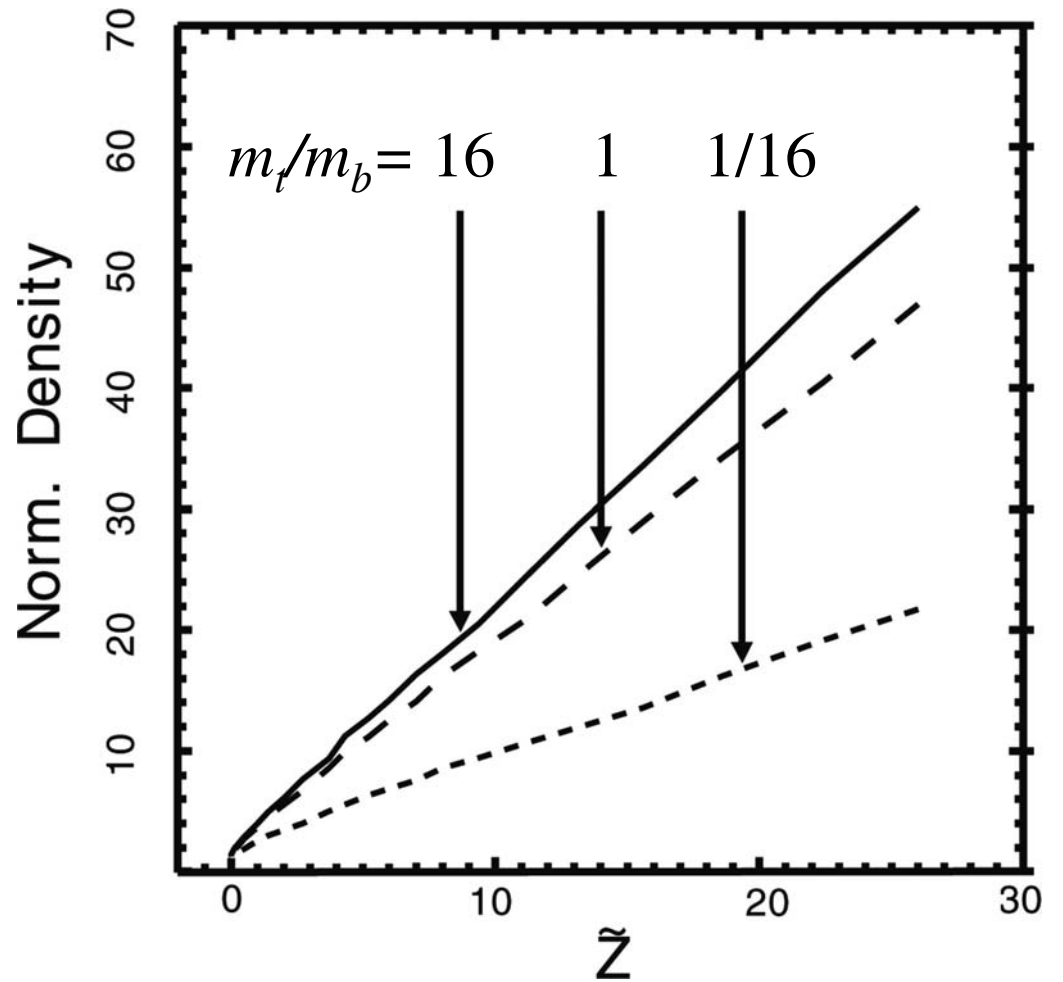

3.b. Collisional Polar Wind

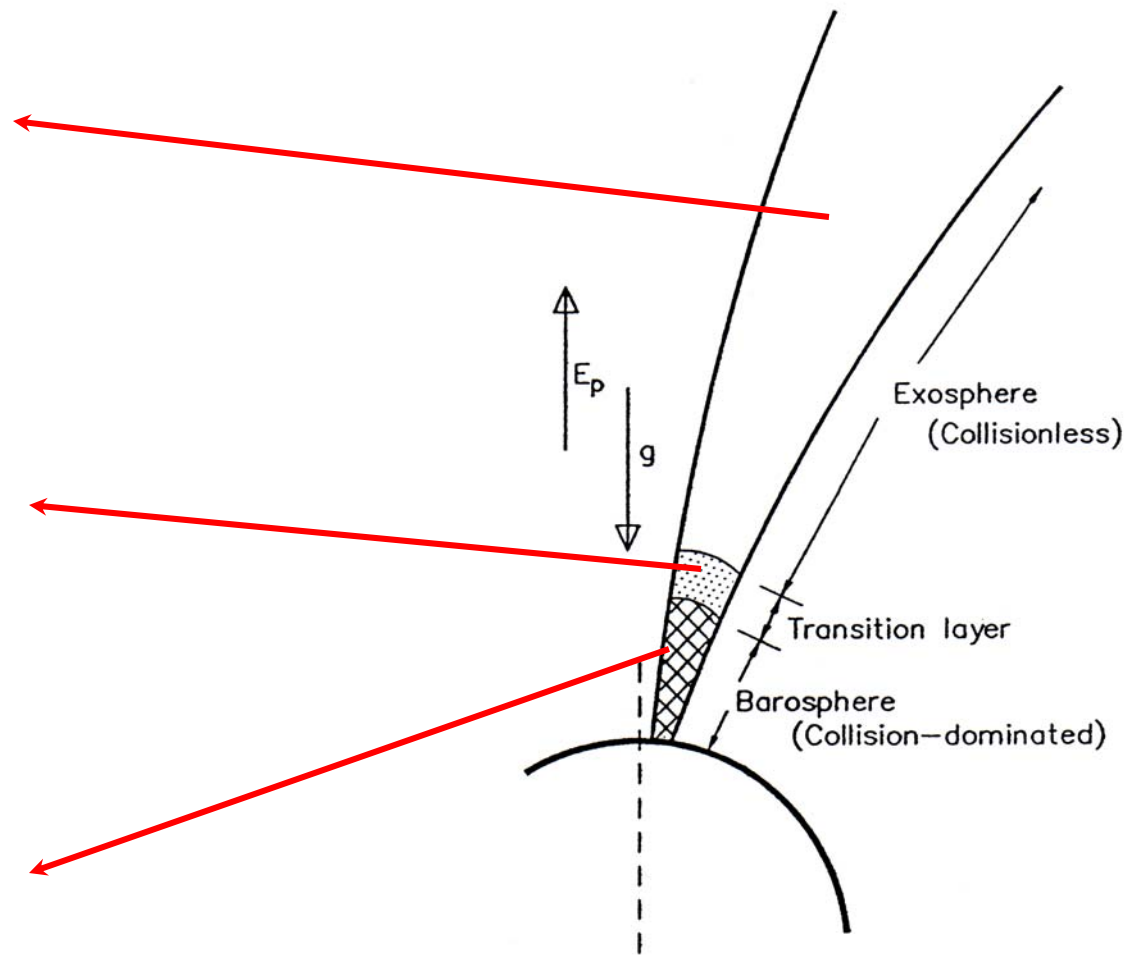
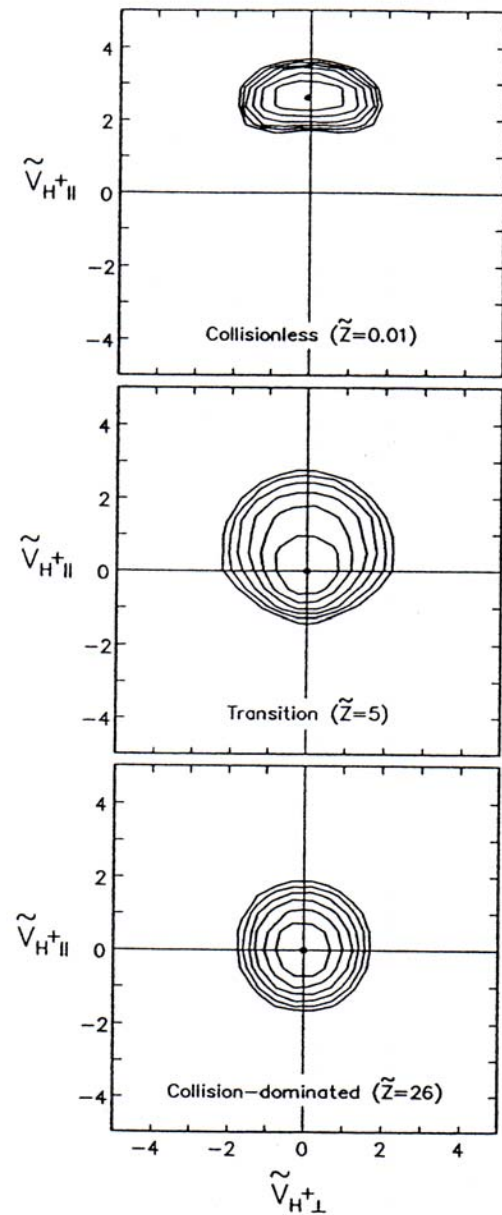

[Barghouthi et al., 1993]

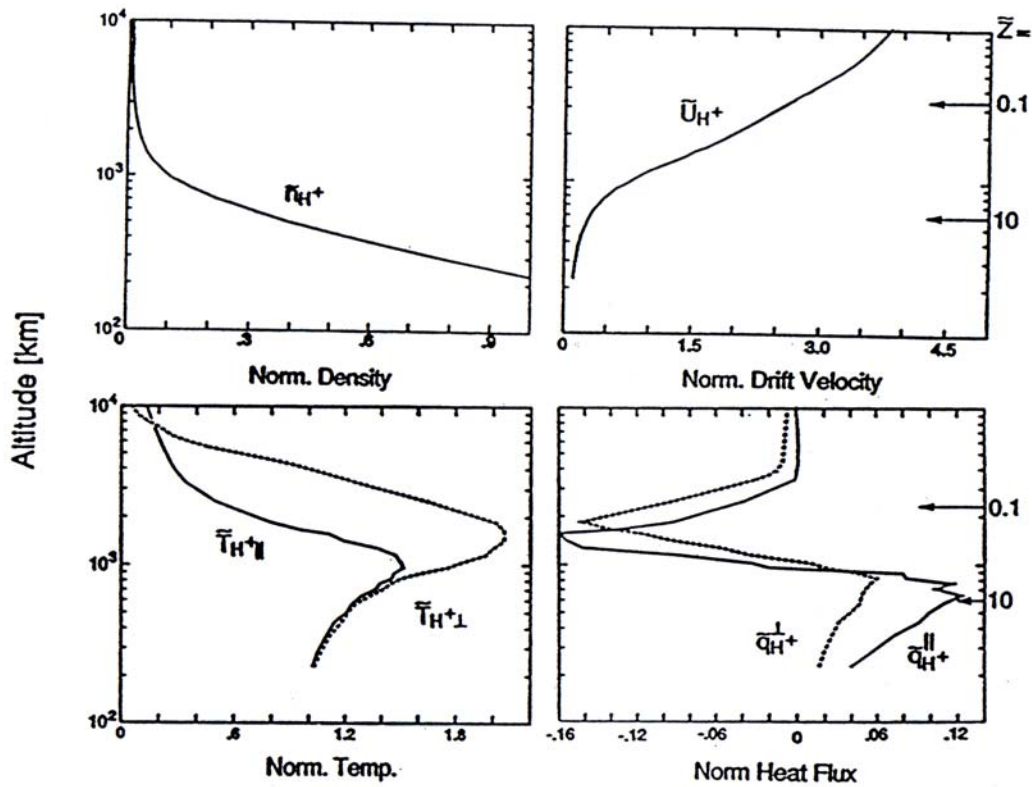

[Barghothi et al., 1993]

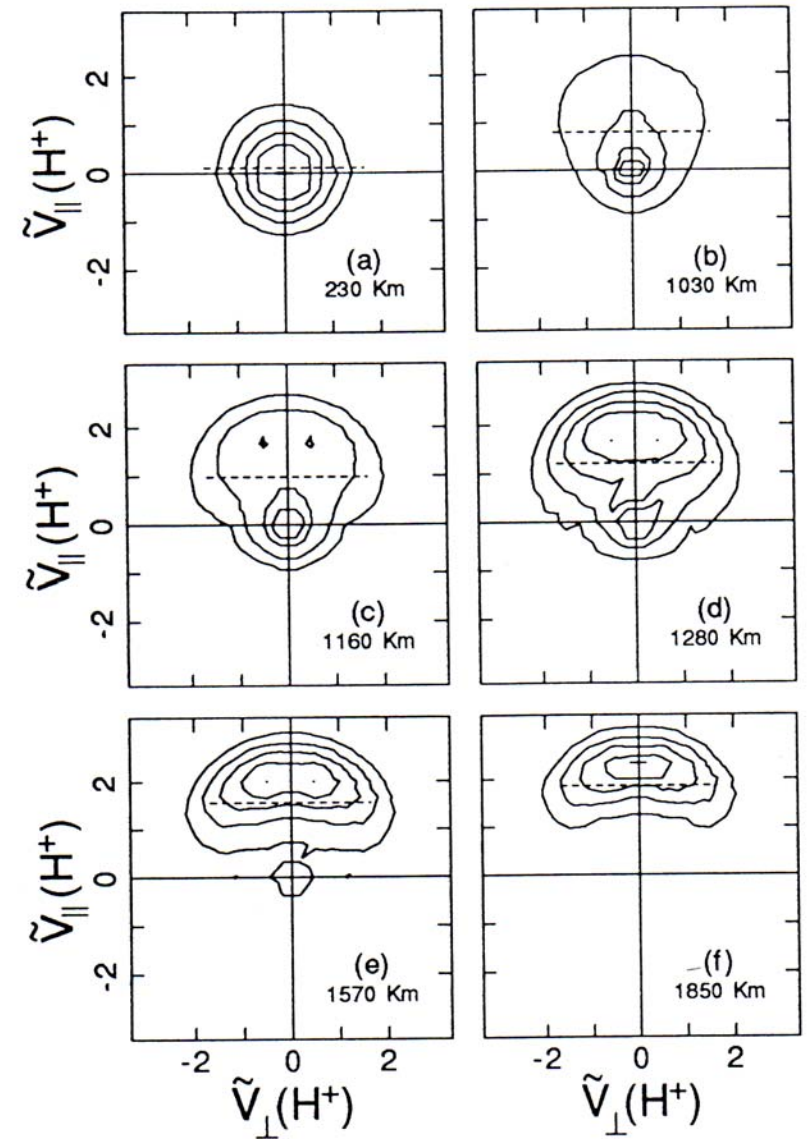

[Barakat et al., 1995]

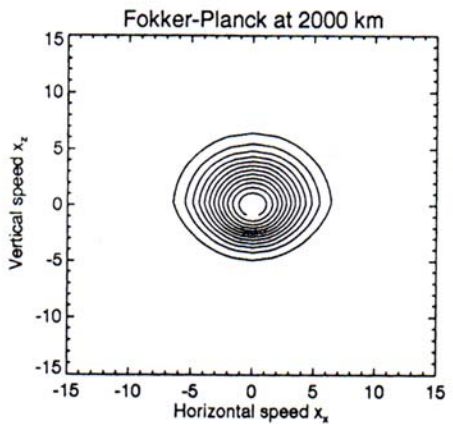
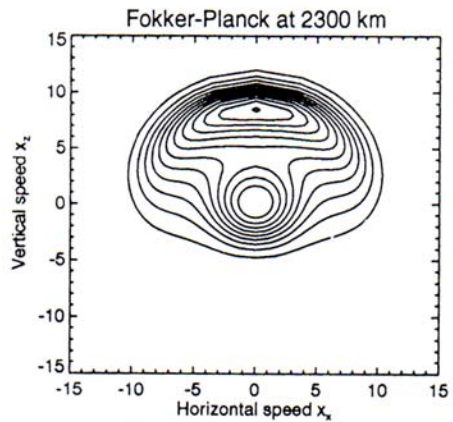
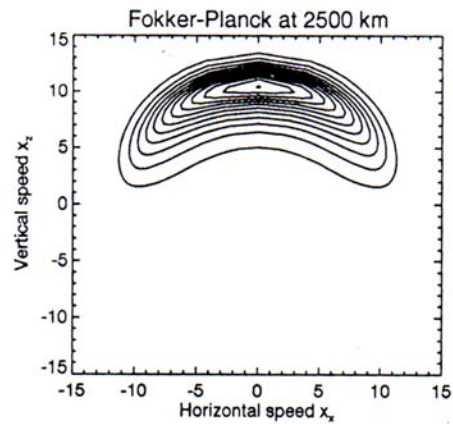

- Boltzmann equation (PDE)
- Fokker-Planck collision
- Finite difference method

[*Lie-Svendsen and Reese, 1996*]

3.c. Wave-particle interaction

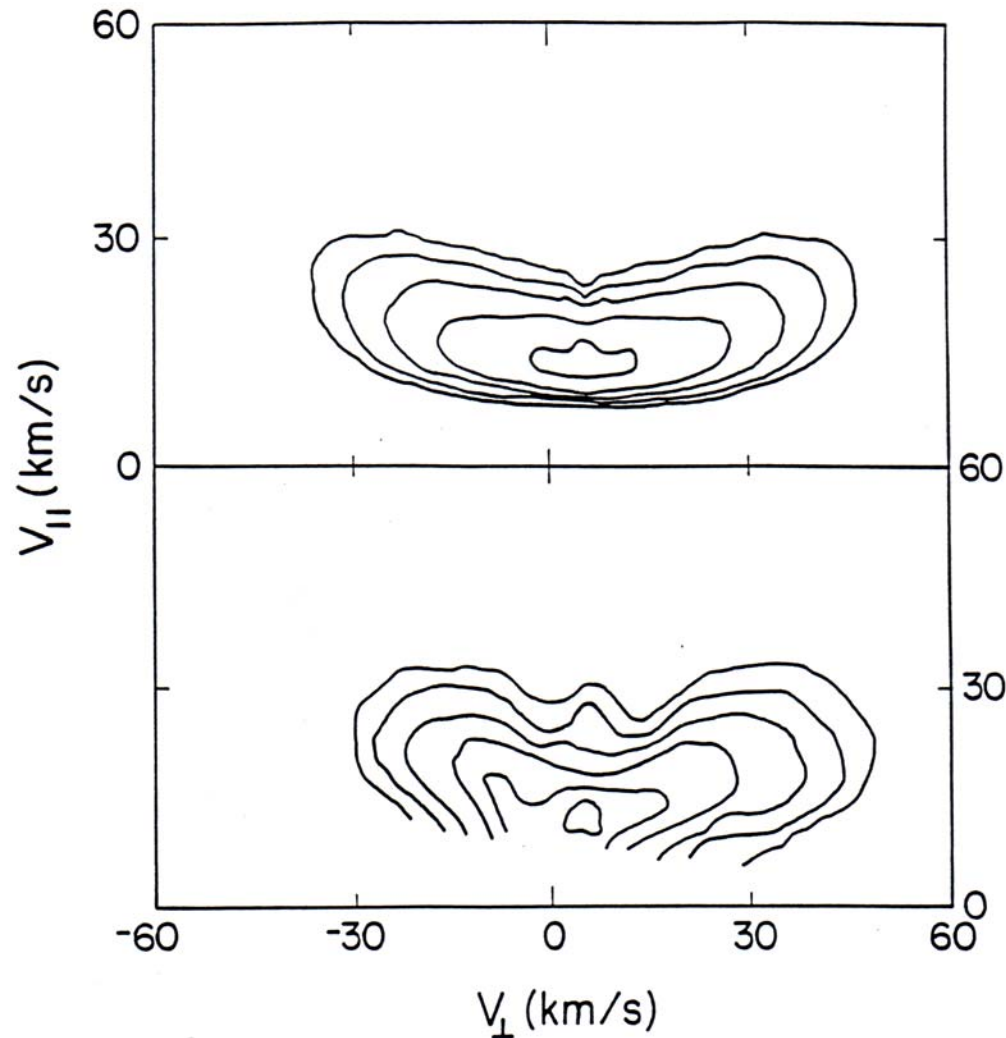

- Auroral field line
- Diffusion in the velocity space
- Conics

[Crew *et al.*, 1988]

$f(\text{H}^+)$

$\lambda = 100 \text{ Km}$

$\lambda = 10 \text{ Km}$

$\lambda = 1 \text{ Km}$

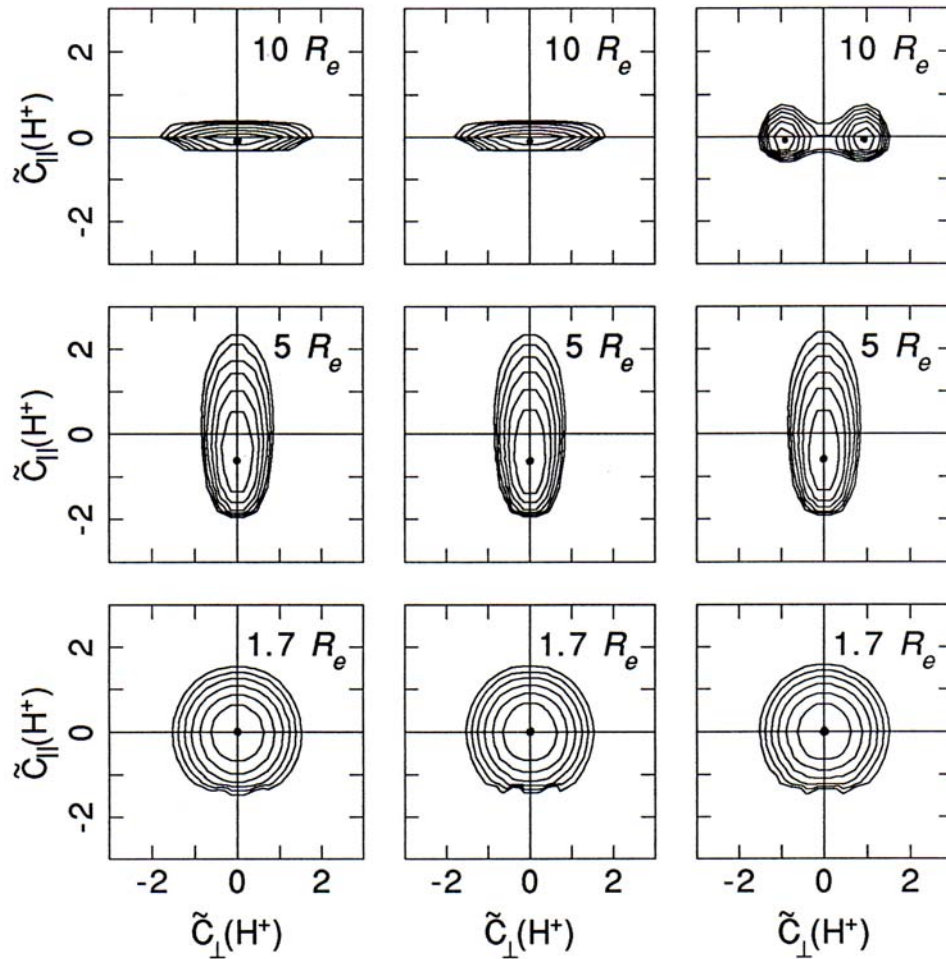

- Altitude-dependent WPI
- Finite Larmor radius
- Concis and toroidal VDF's

[Barghouthi et al., 1998]

3.d. Mac-PIC model

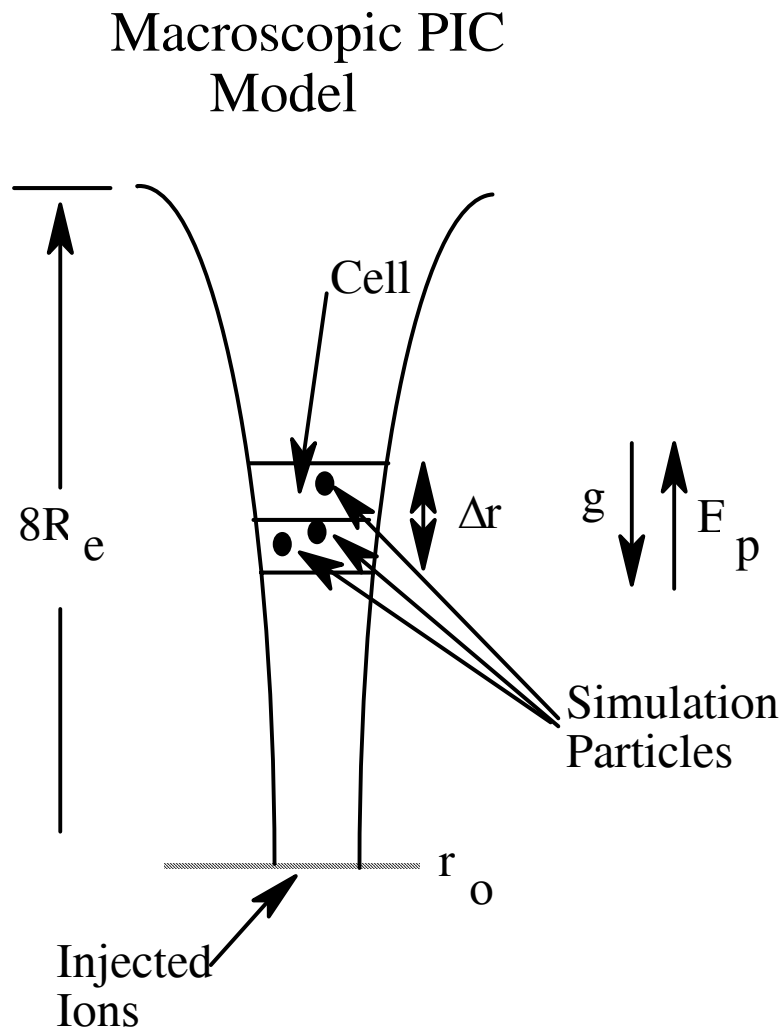

- Ion-ion collision
- WPI
- Gravity
- Magnetic mirror
- $\mathbf{E} \times \mathbf{B}$ convection
- $\sim 1,000,000$ particles
- ...etc

4. 3-D Problems

- ~1000 flux tube simulation

- Model accounts for:
 - Low-altitude energization
 - Storm
 - $E \times B$ drift
 - Polar rain
 - Wave-Particle interactions
 - ... Etc.

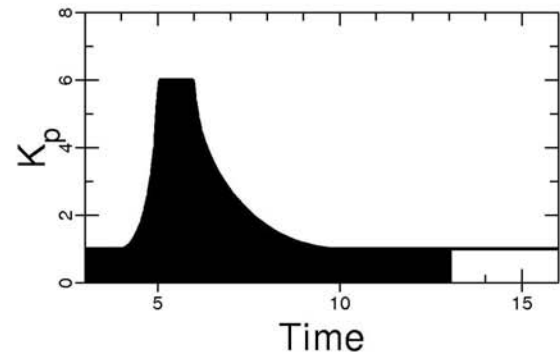
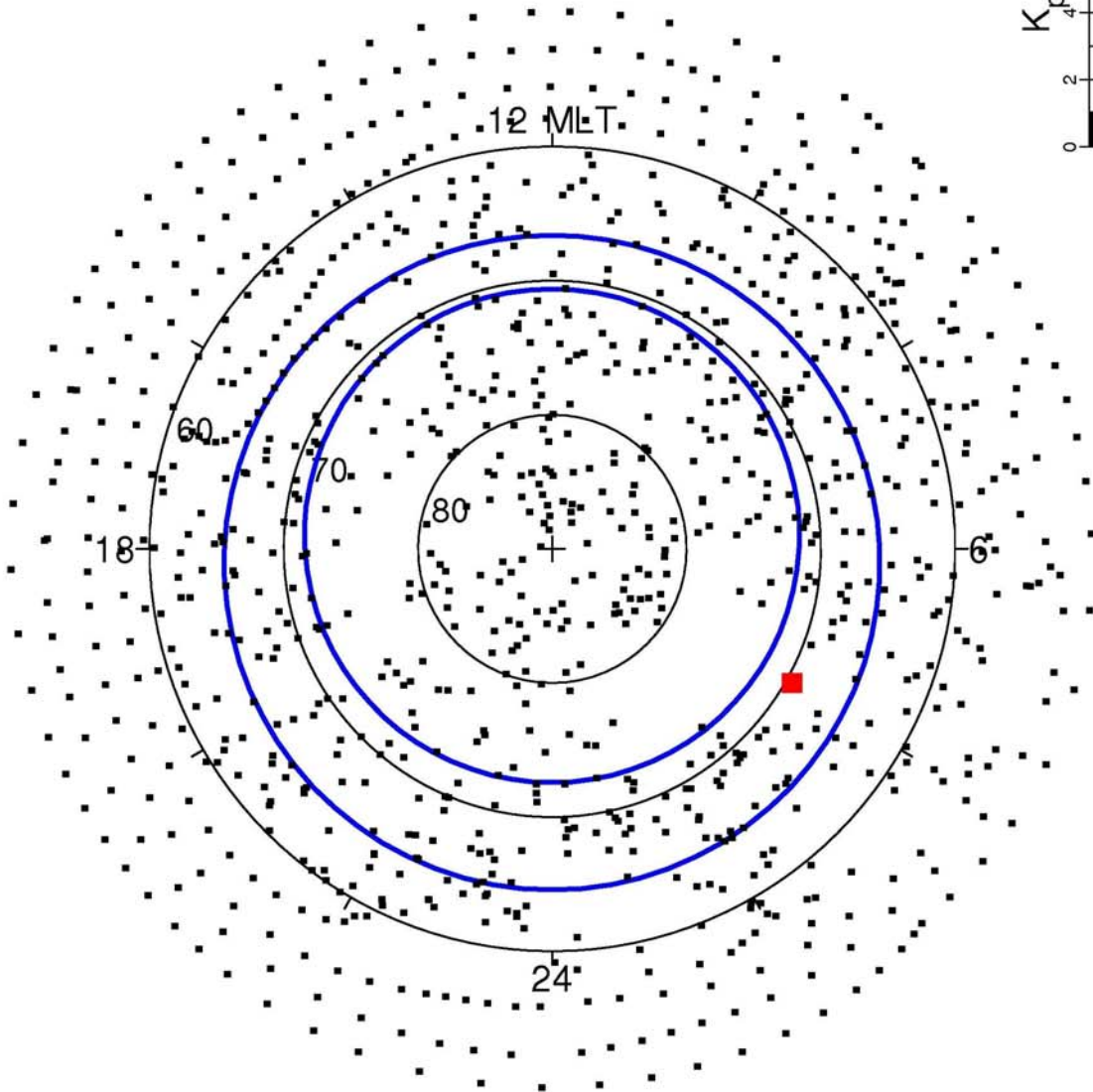

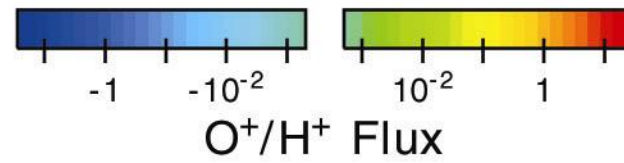
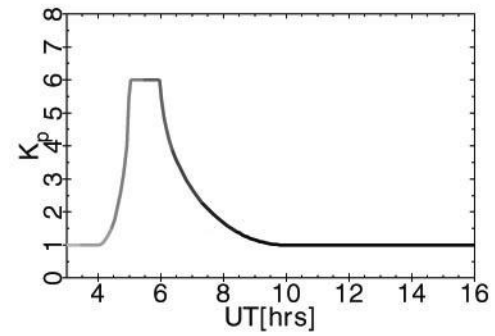
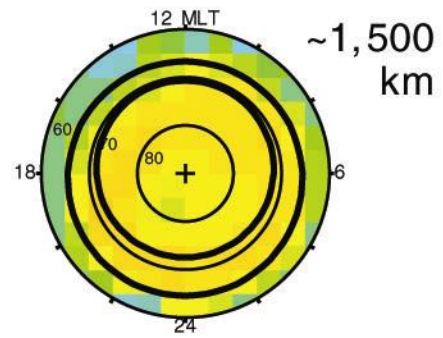
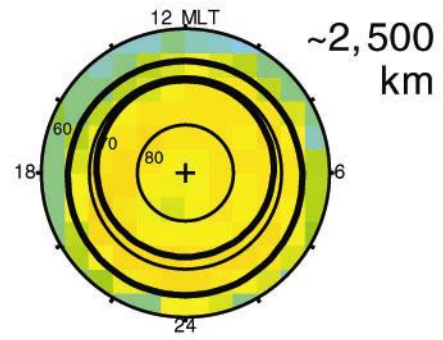
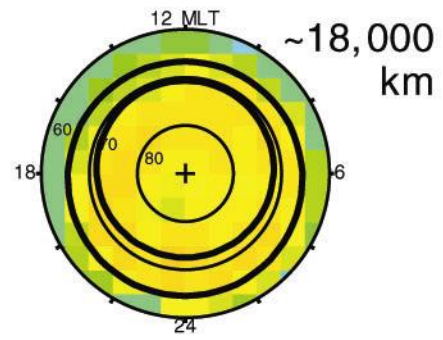

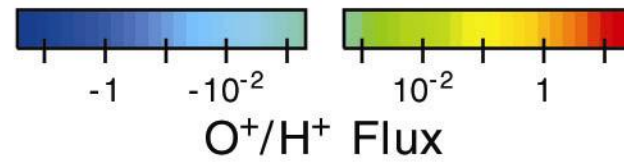
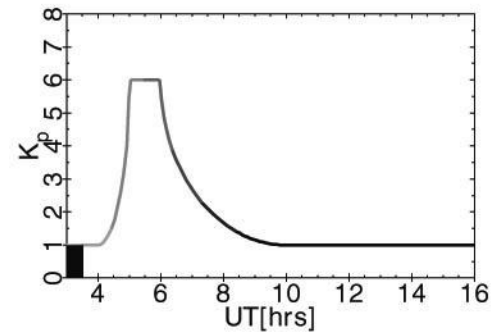
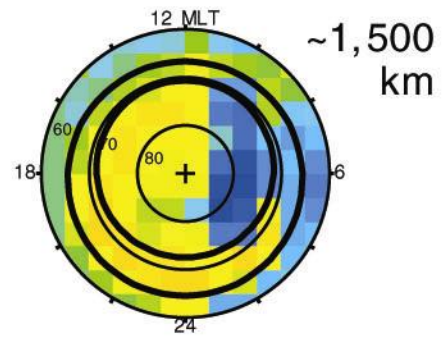
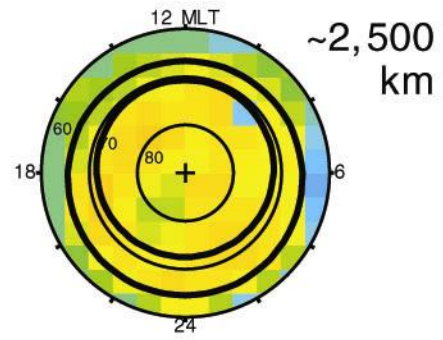
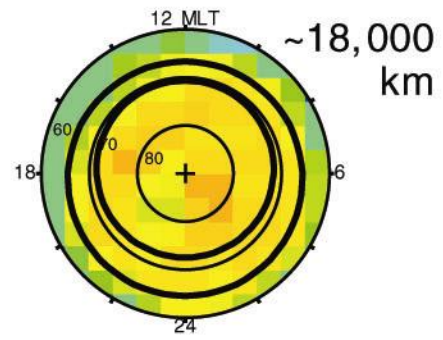

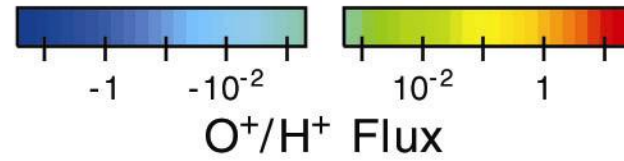
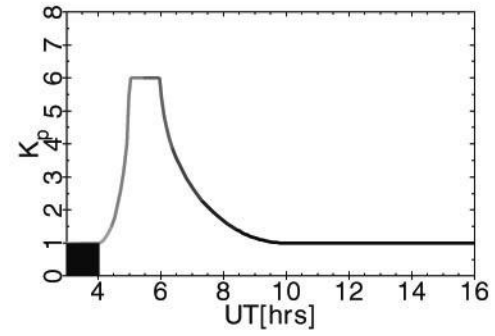
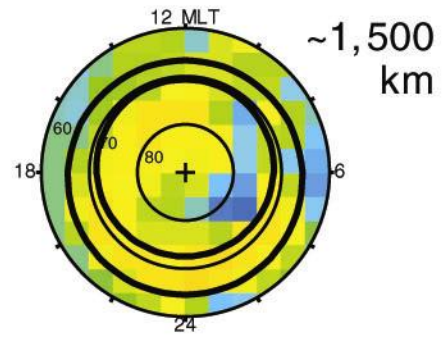
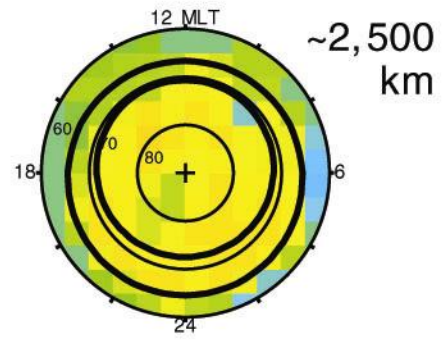
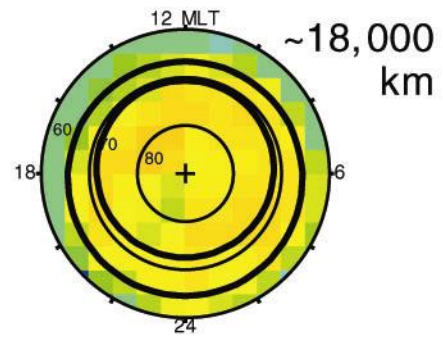

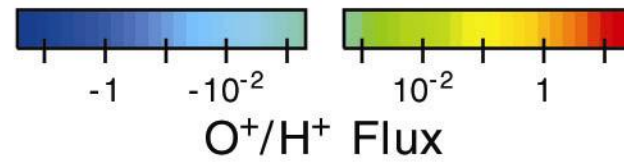
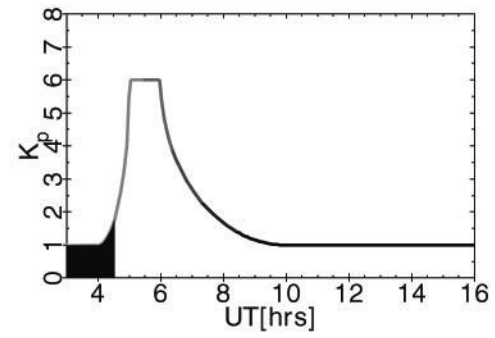
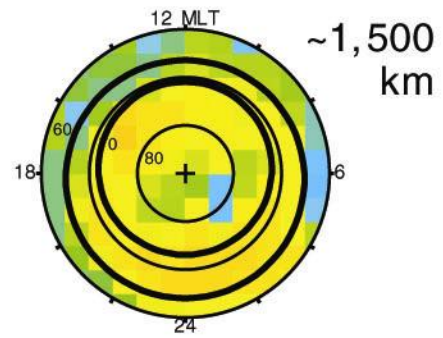
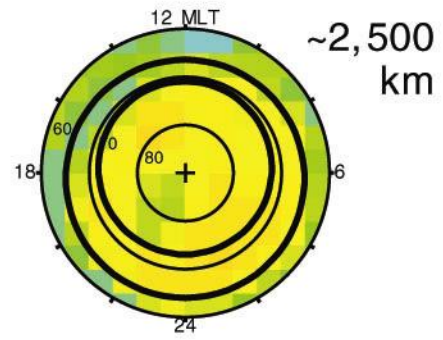
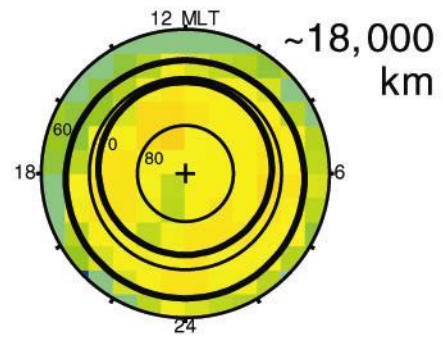

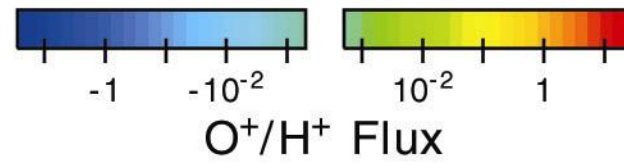
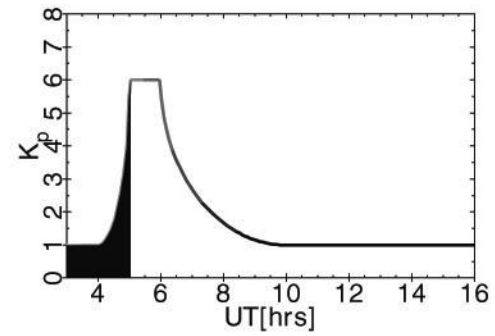
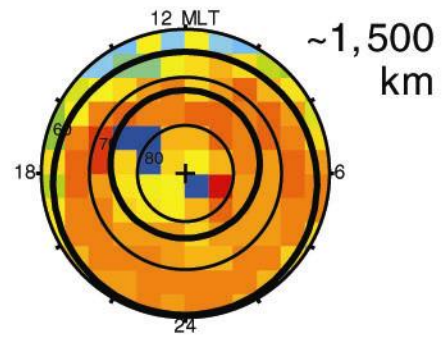
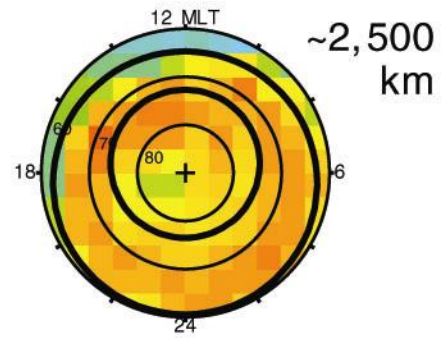
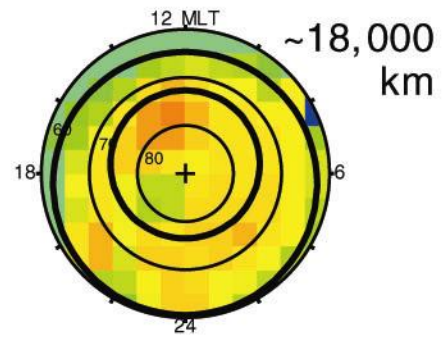

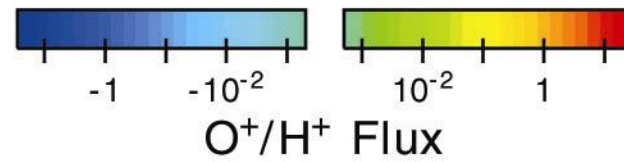
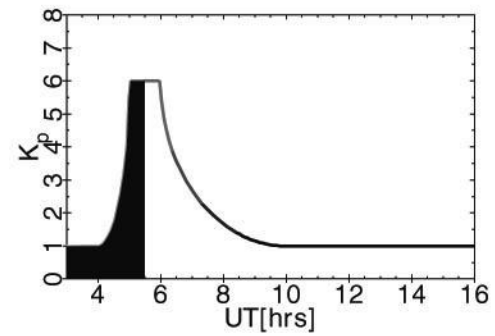
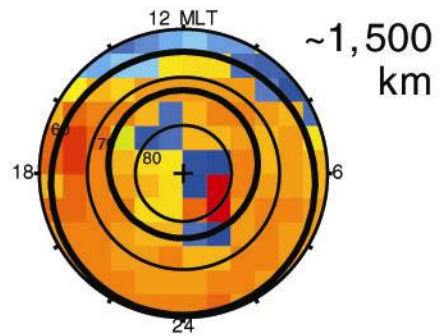
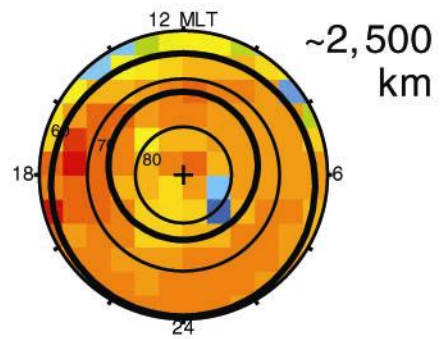
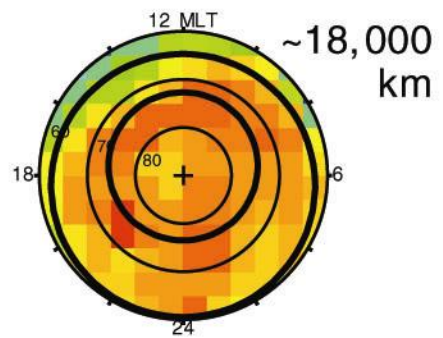

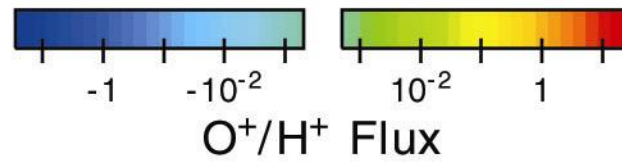
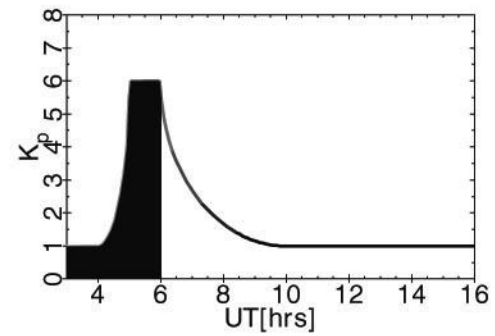
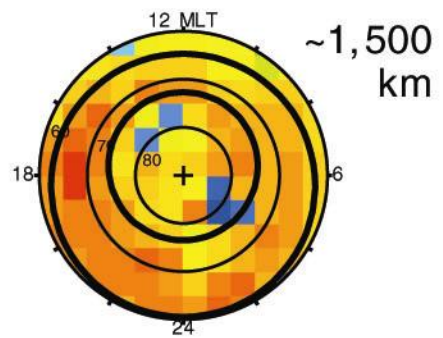
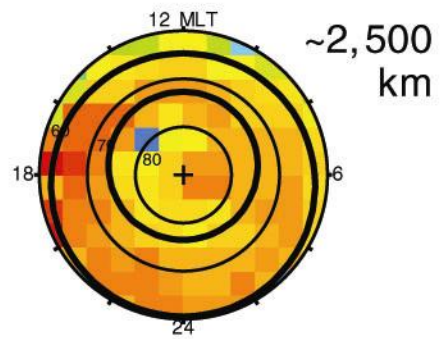
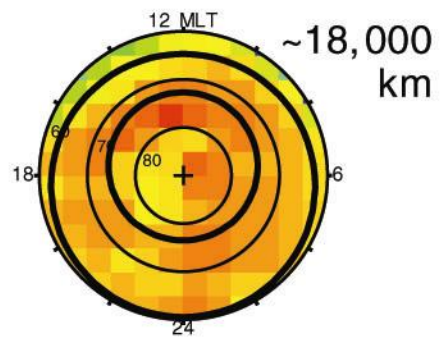

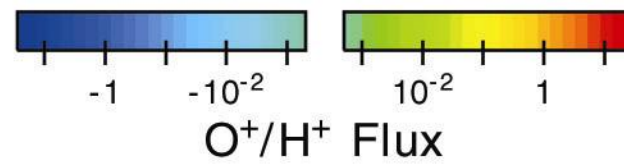
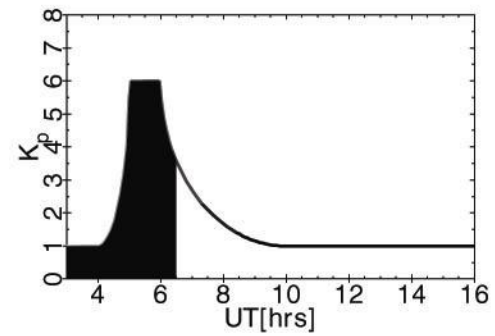
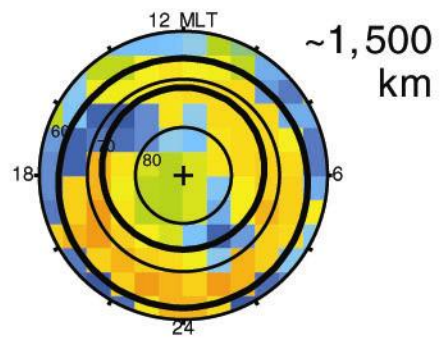
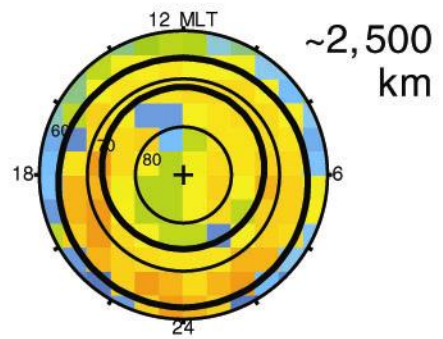
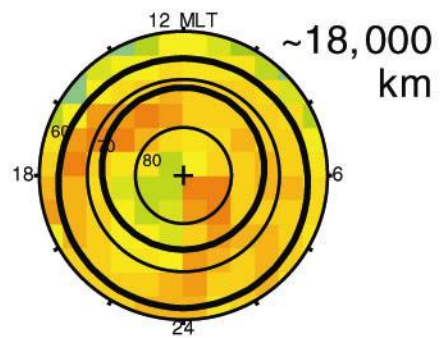

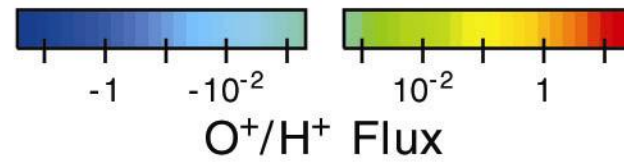
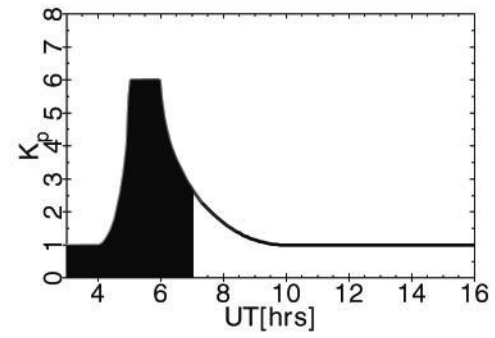
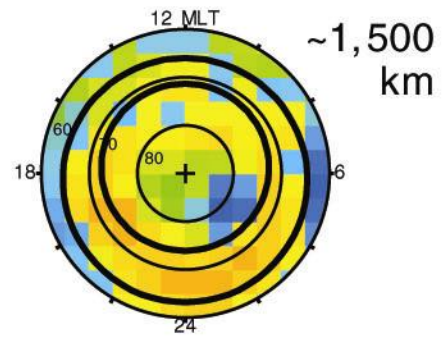
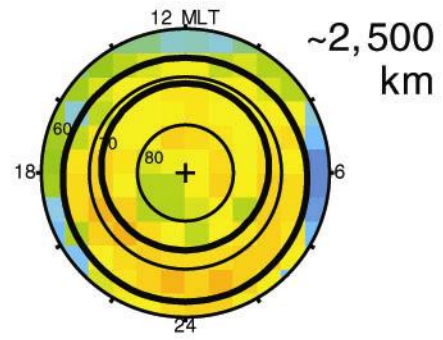
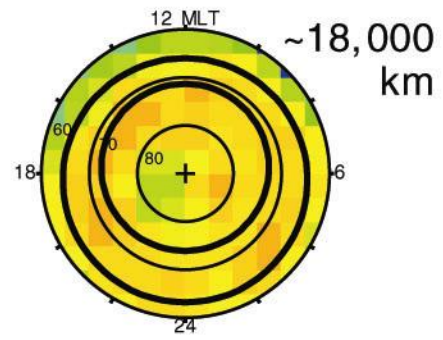

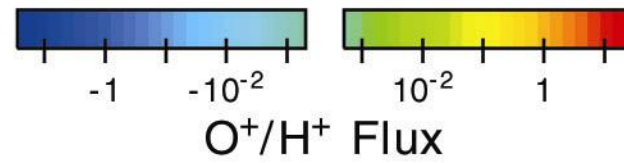
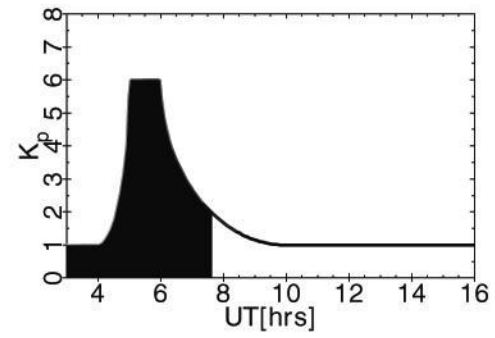
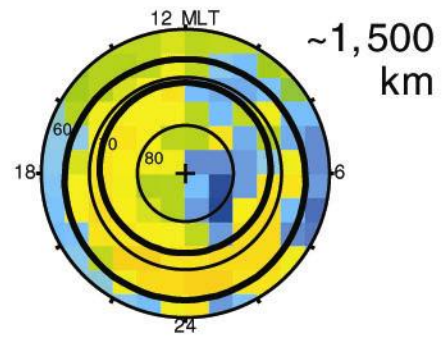
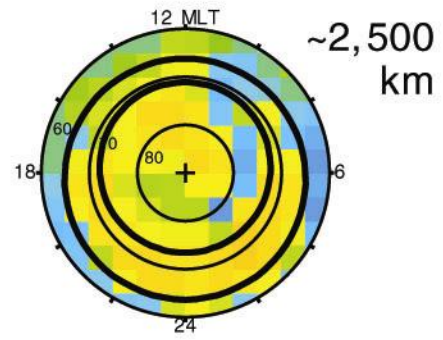
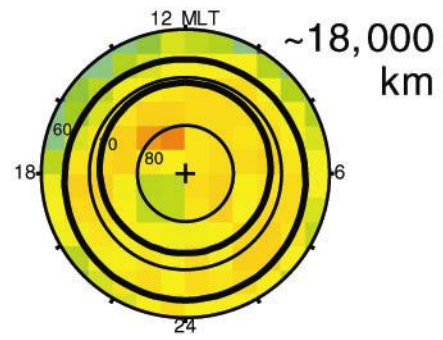

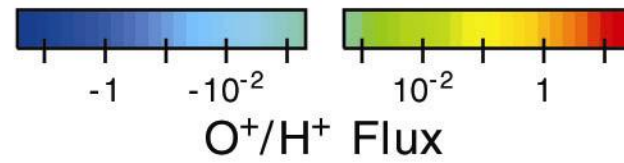
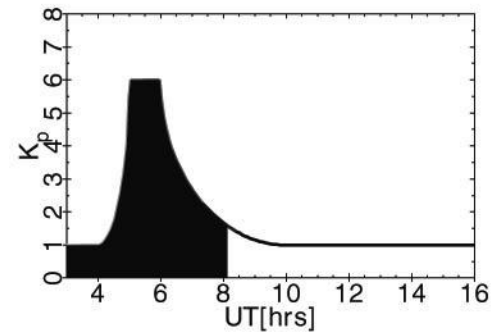
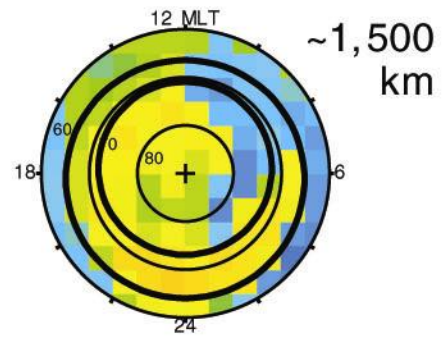
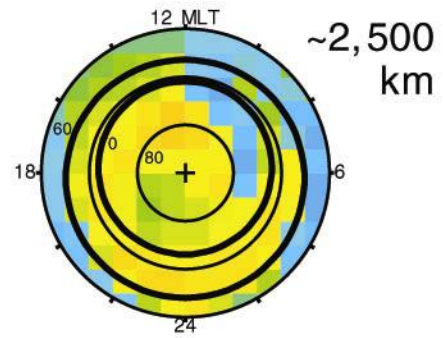
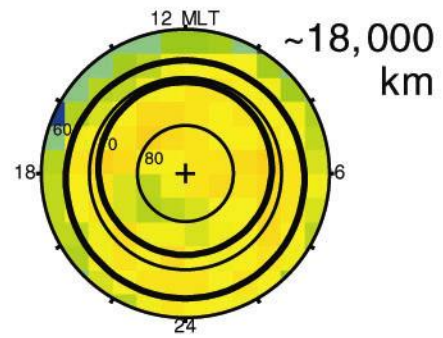

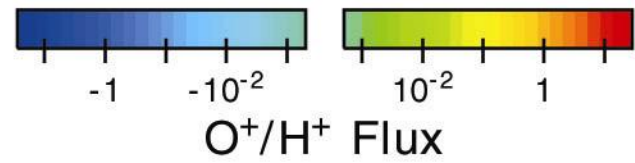
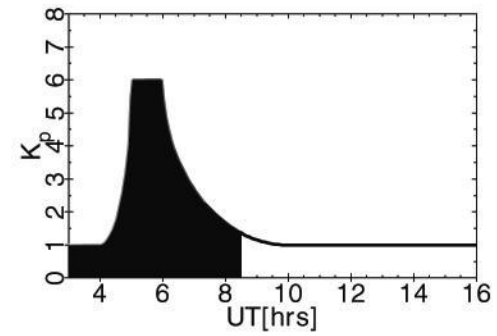
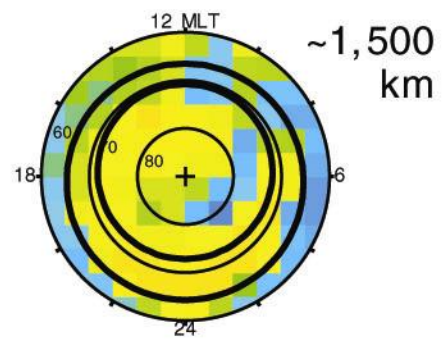
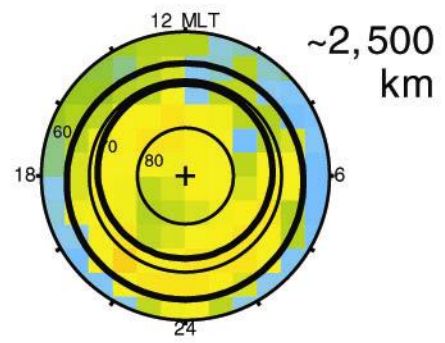
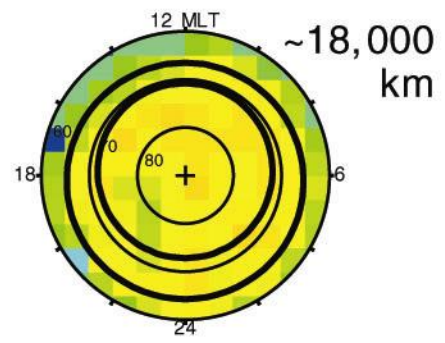

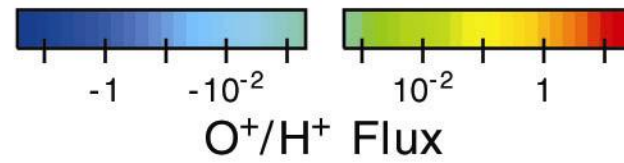
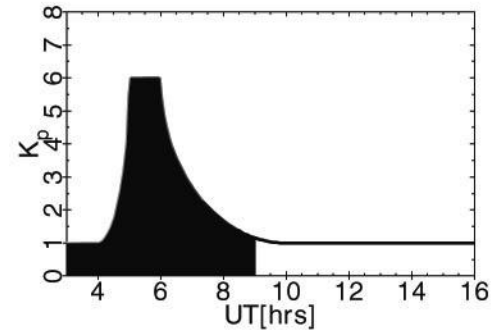
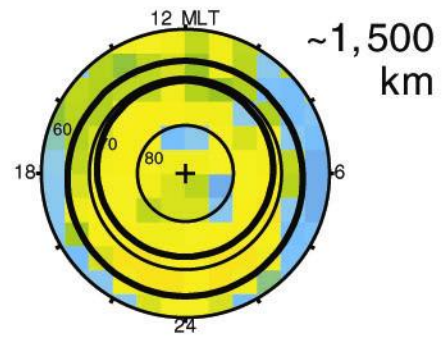
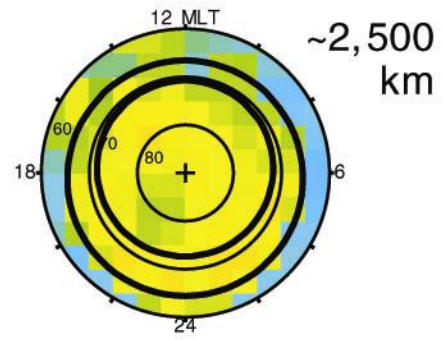
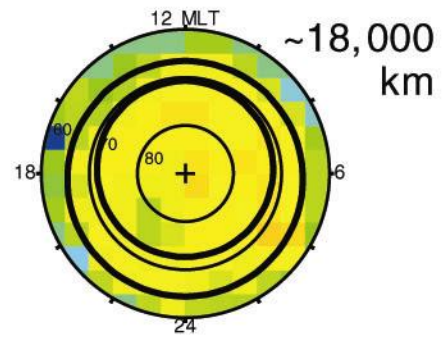

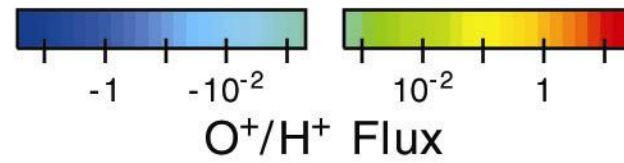
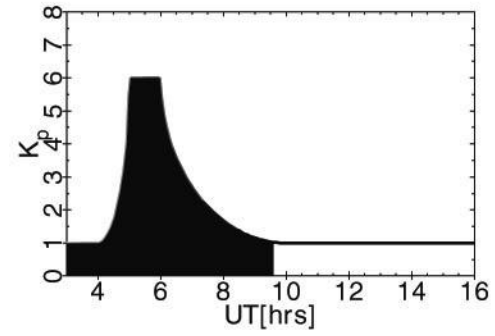
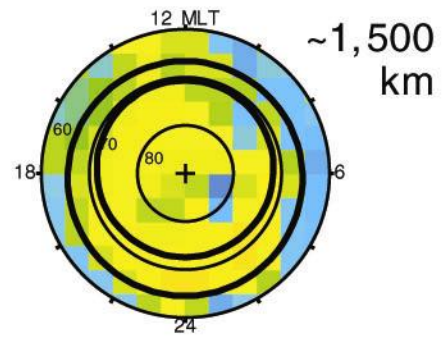
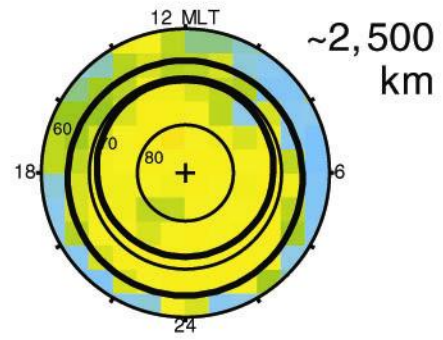
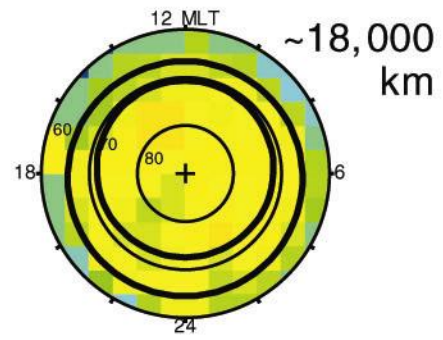

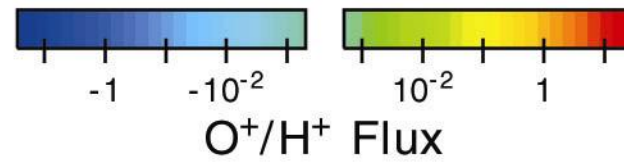
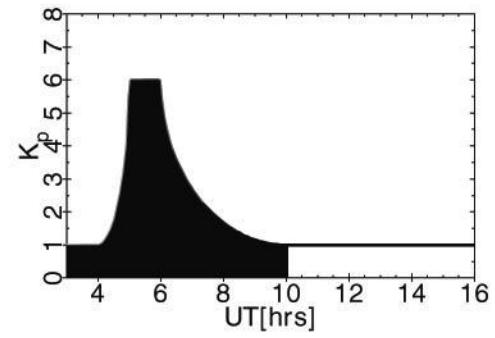
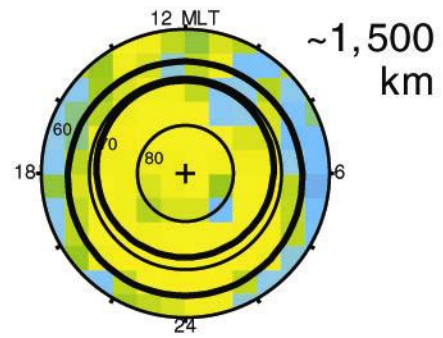
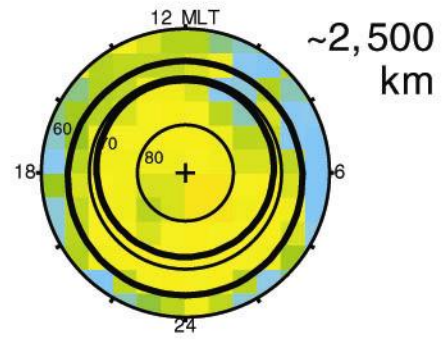
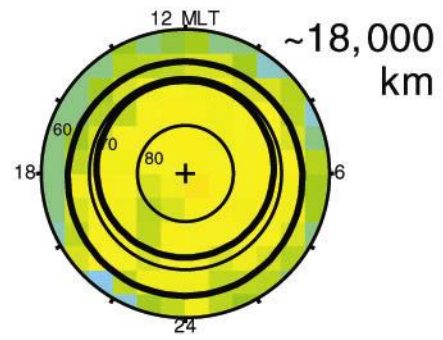

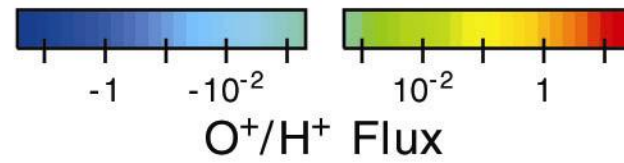
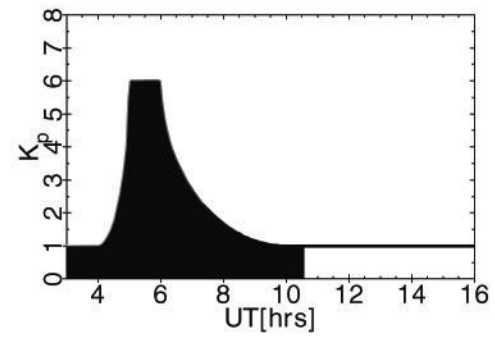
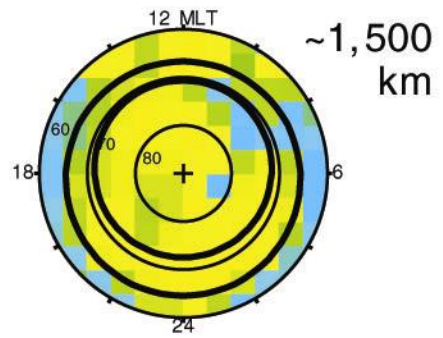
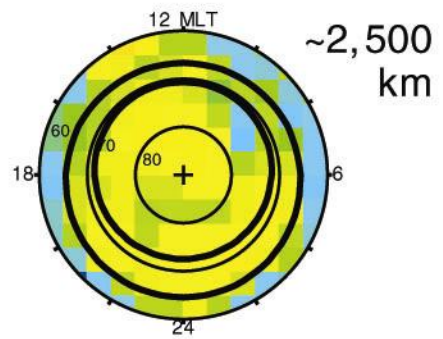
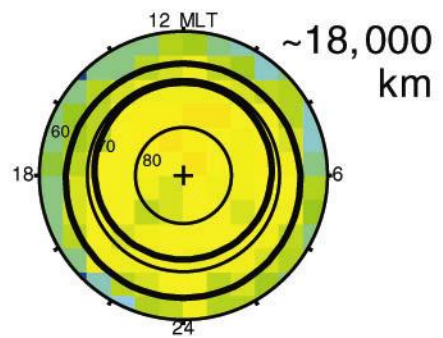

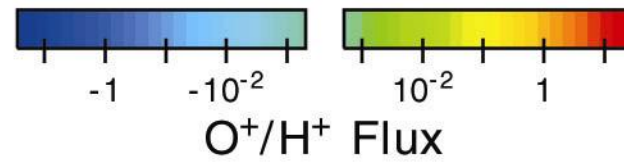
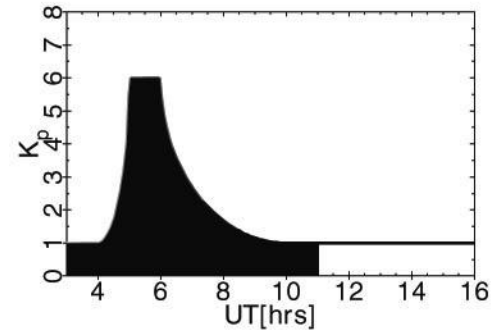
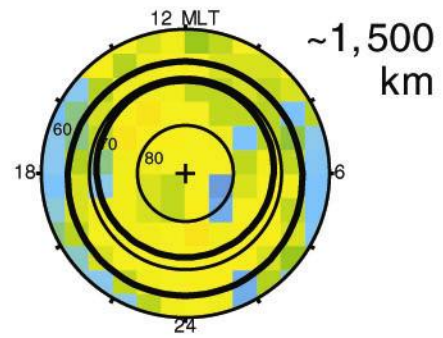
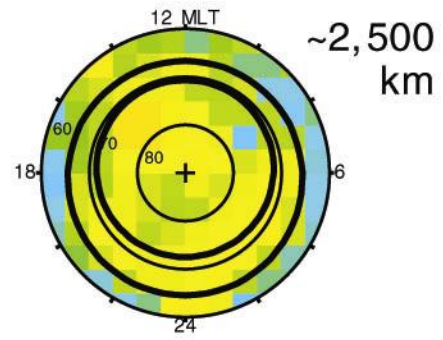
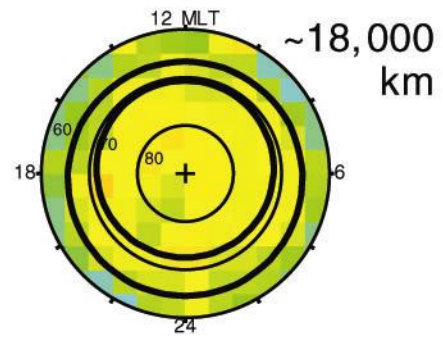

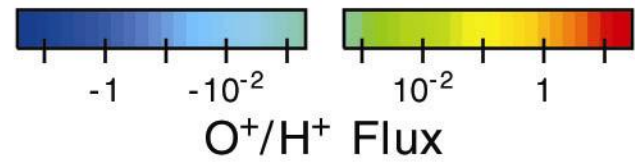
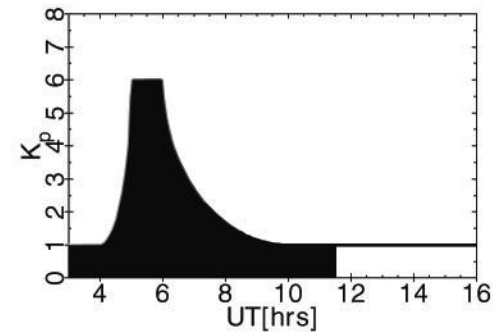
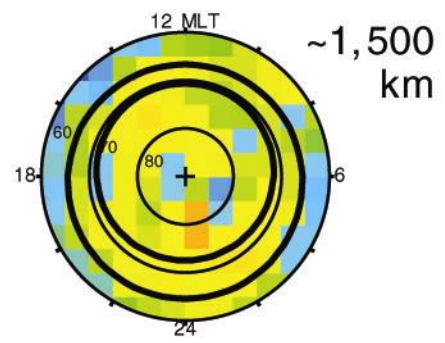
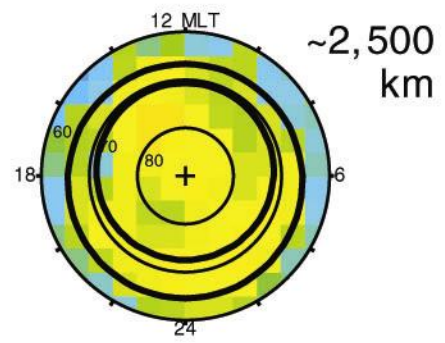
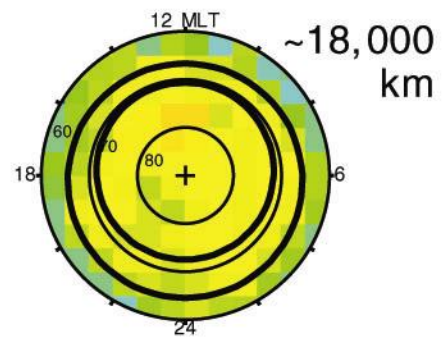

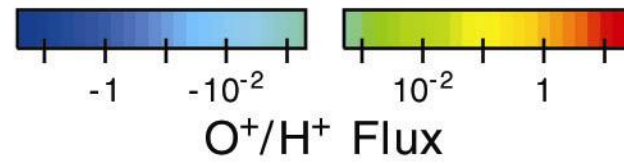
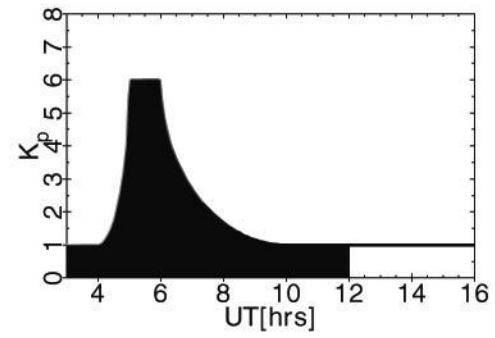
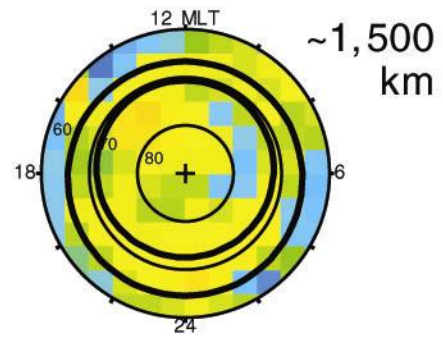
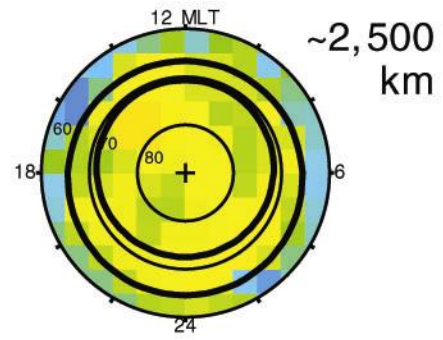
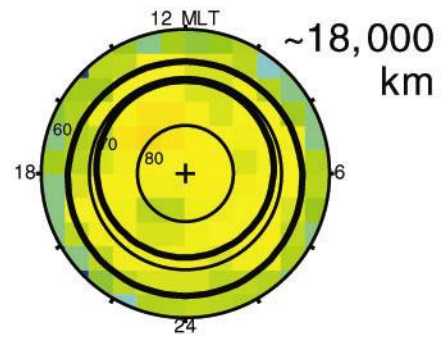

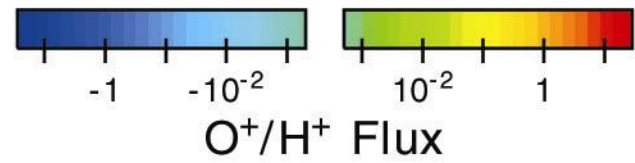
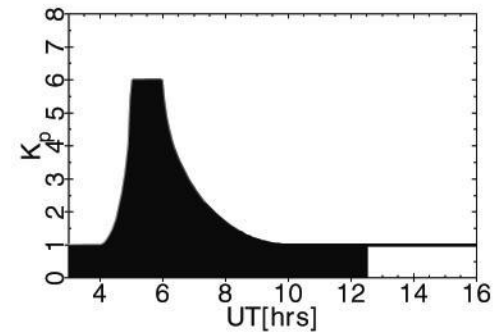
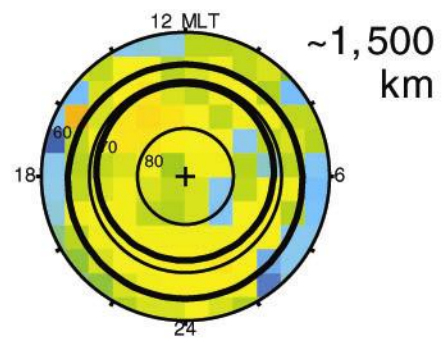
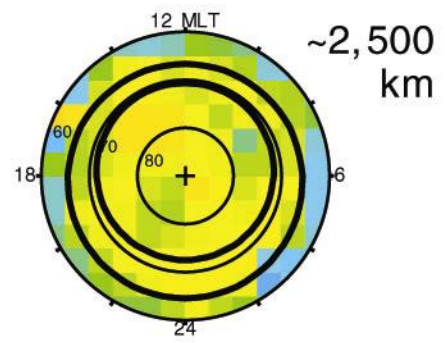
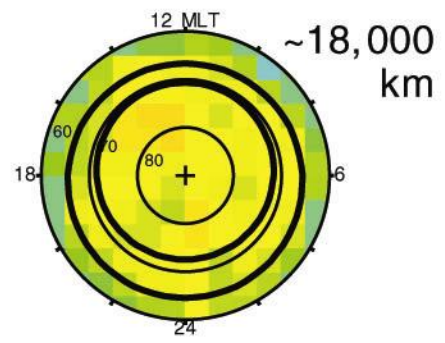

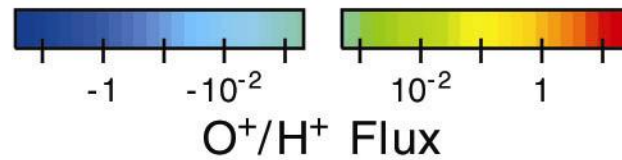
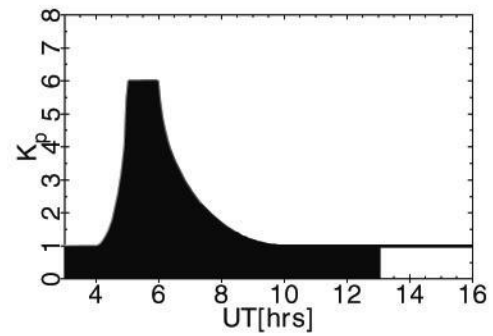
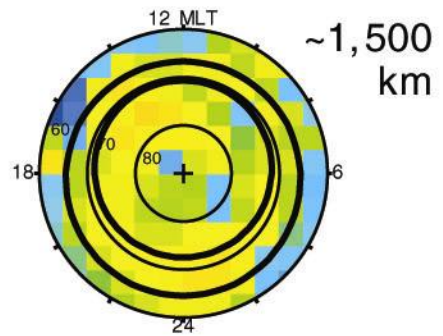
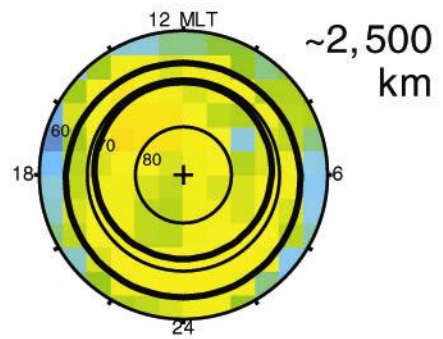
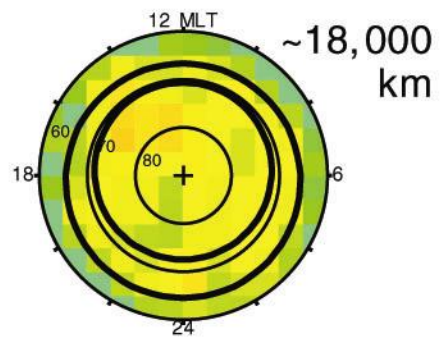

5. Efficiency Improvement Techniques

Incoherent Scattering Radar

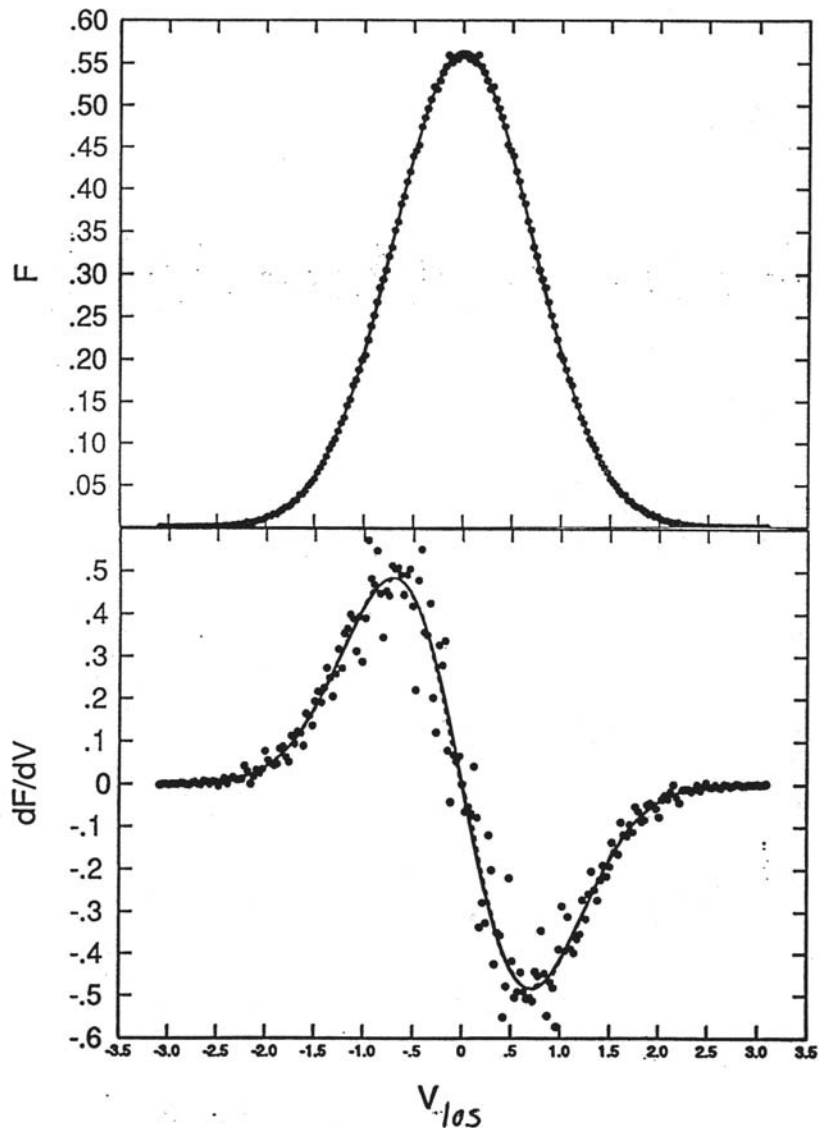

$$S \sim dF/dV_{los}$$

1. M.C. $\rightarrow F(V_{los}), \sigma_F(V_{los})$
2. Fit a spline in F .
3. Compute dF/dV_{los} directly from the spline.

[Elssamdisy et al., 1992]

6. Summary

Decade	Dim	#	Time Dependence	# Processors
50's	0-D	10^4 collisions	S.S.	1
60's	0-D			
70's	0-D	10^5 collisions	S.S.	1
80's	1-D	10^6 collisions	S.S.	1
90's	1-D	10^6 particles	Dynamic	1
00's	3-D	10^9 particles	Dynamic	$> 10^3$

- Advantages

- Simple algorithm
- Robust
- Suitable for parallel computations (embarrassingly parallel)
- Random errors (no systematic error)

- Limitations

- Error $\sim (N)^{1/2}$
- Limited number of significant digits
- Computationally intensive
- Depends on the statistical properties of the pseudorandom number sequence